

# Communication Interface Module Replacement

## Removal Procedure

**Important:** The vehicle communication interface module (VCIM) has a specific set of unique numbers that tie the module to each vehicle. These numbers, the 10-digit station identification and the 11-digit electronic serial number, are used by the National Cellular Network and OnStar® to identify the specific vehicle. Because these numbers are tied to the vehicle identification number of the vehicle, you must never exchange these parts with those of another vehicle.

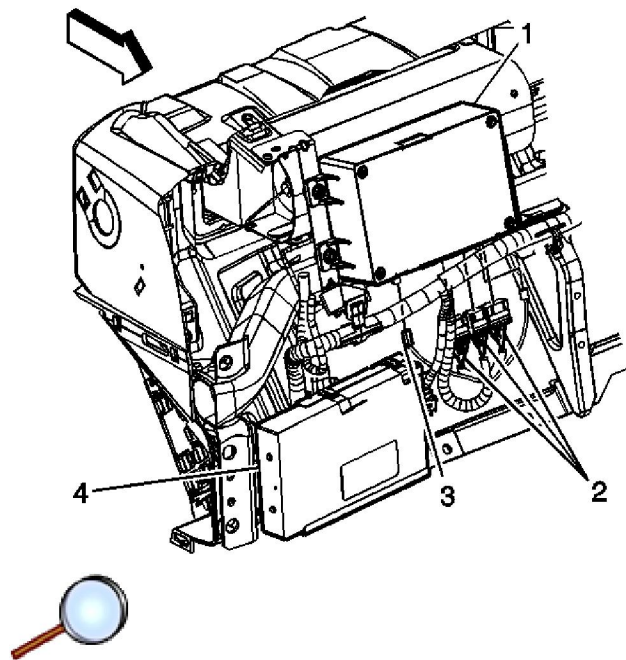

1. Remove the instrument panel (I/P) upper trim panel. Refer to [Instrument Panel Upper Trim Panel Replacement](#).
2. Fully open the I/P storage compartment.
3. Disconnect the electrical connectors (2) from the VCIM (1).
4. Disconnect the coaxial cable (3) from the VCIM.

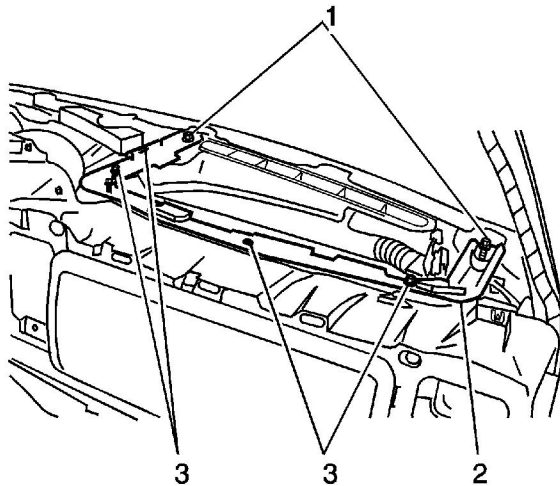

5. Remove the screws (1, 3) from the passenger side upper I/P support (2).
6. Remove the passenger side upper I/P support (2).

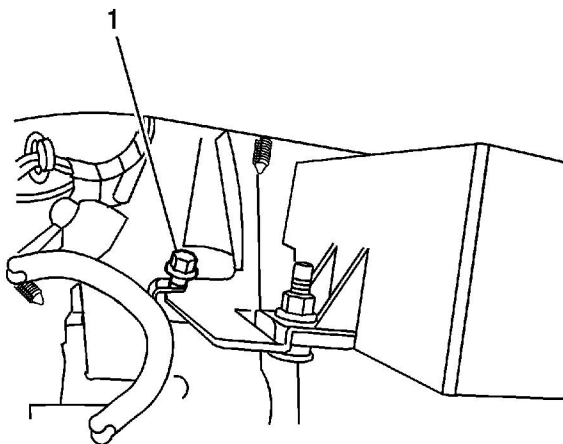

7. Remove the screw (1) retaining the VCIM bracket to the I/P.
8. Remove the retainer from the VCIM bracket.
9. Remove the nuts holding the mounting brackets to the VCIM.
10. If necessary, move the cross-car duct forward slightly in order to make room for the removal of the module.

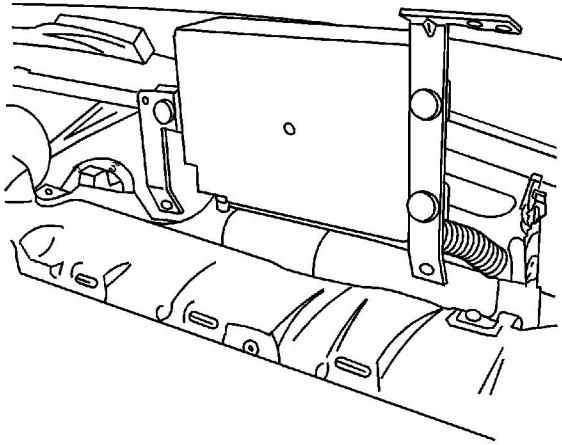

11. Remove the VCIM and bracket assembly from the I/P.

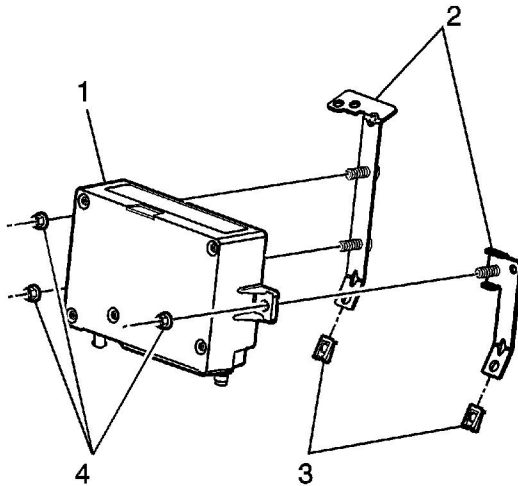

12. Remove the nuts (4) from the VCIM mounting brackets (2).  
13. Remove the mounting brackets (2) from the VCIM (1).

## Installation Procedure

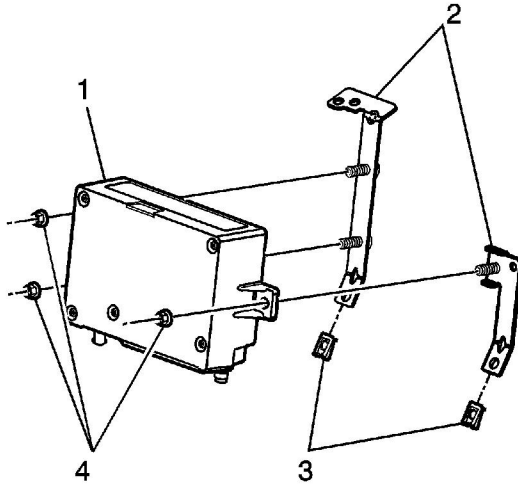

1. If replacing the VCIM, record the 10-digit STID number, and the 11-digit ESN number from the labels on the new module.
2. Ensure the nuts (3) are installed on the module mounting brackets (3).
3. Install the mounting brackets (2) to the VCIM (1).

**Notice:** Refer to [Fastener Notice](#) in the Preface section.

4. Install the nuts (4).

#### **Tighten**

Tighten the nuts to 2 N·m (18 lb in).

5. If necessary, move the cross-car duct forward slightly in order to make room for the installation of the module.

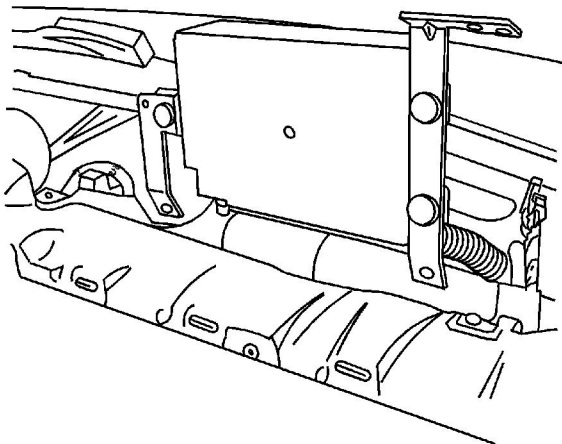



6. Install the VCIM and bracket assembly to the I/P.
7. Install the push in retainer.

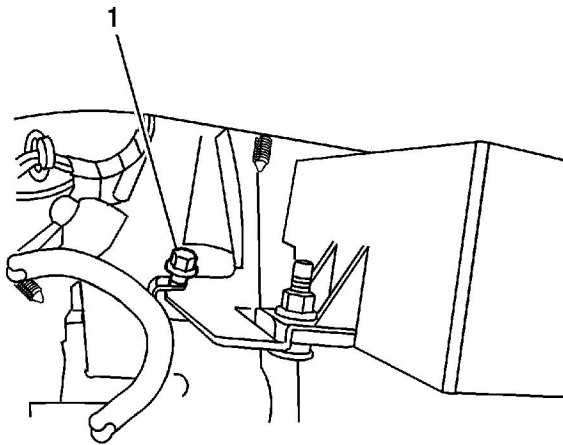

8. Install the VCIM screw (1) to the I/P.

**Tighten**

Tighten the screws to 2 N·m (18 lb in).

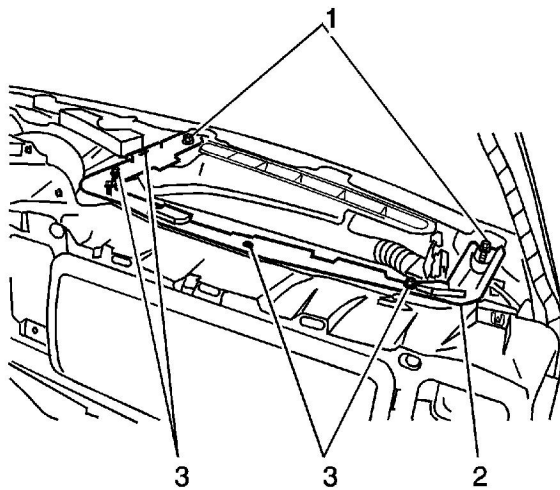

9. Install the passenger side upper I/P bracket (2).
10. Install the I/P upper bracket screws (3).

**Tighten**

Tighten the screws (3) to 2 N·m (18 lb in).

11. Install the I/P upper bracket screws (1).

**Tighten**

Tighten the screws (1) to 50 N·m (37 lb ft).

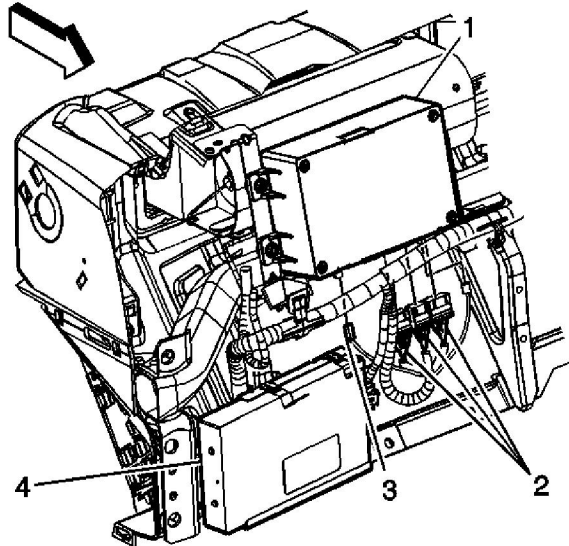

12. Connect the coaxial cable (3) to the VCIM.
13. Connect the electrical connectors (2) to the VCIM.
14. Install the I/P trim panel. Refer to [Instrument Panel Upper Trim Panel Replacement](#) .

**Important:** After replacing the vehicle communication interface module, you must reconfigure the OnStar® system. Failure to reconfigure the system will result in an additional customer visit for repair. In addition, pressing and holding the white dot button on the keypad will NOT reset this version of the OnStar® system. This action will cause a DTC to set.

15. Reconfigure the OnStar® system. Refer to [OnStar Reconfiguration](#) .